

## 5-CHANNEL OPERATIONAL AMPLIFIER, IRIS DRIVER, AND 4-CHANNEL H-BRIDGE DRIVER

### DESCRIPTION

The  $\mu$  PD168103 is the motor driver IC with IRIS control circuit, operational amplifier and 4-ch H-bridge output. Smooth operation is possible for IRIS control with linear method.

The package is 48-pin thin type QFN and then it helps reduce the mounting area and height.

The  $\mu$  PD168103 is suitable for the lens drive of a camcorder, DSC, etc.

### FEATURES

- 5-ch H-bridge circuits employing power MOS FET
- Low-voltage driving  
LV<sub>DD</sub> = 2.7 to 3.6 V, AV<sub>DD</sub> = 4.5 to 5.5 V, V<sub>M12</sub> = V<sub>M34</sub> = V<sub>SHUTTER</sub> = V<sub>IRIS</sub> = 2.7 to 5.5 V
- Output on-state resistance: 2.0  $\Omega$  TYP., 3.0  $\Omega$  MAX. (4-ch H-bridge block, sum of top and bottom stage, V<sub>M</sub> = 5 V)
- PWM output (ch1 to ch4)
- Output current  
DC current:  $\pm 0.3$  A/ch (when each channel is used independently)  
Peak current:  $\pm 0.7$  A/ch (when each channel is used independently)
- 3-ch general-purpose operational amplifier  
Input offset voltage:  $\pm 5$  mV  
Input voltage range: 0 to AV<sub>DD</sub> – 1.5 V  
Output voltage range: 0.2 to AV<sub>DD</sub> – 0.2 V
- 1-ch current sink amplifier  
Output current: 5 mA
- 1-ch 1/2V<sub>DD</sub> output amplifier
- IRIS driver block supporting linear driving
- Pre-driver amplifier of the IRIS driver block
- Undervoltage lockout circuit  
Output circuit and amplifier stop at LV<sub>DD</sub> = 1.7 V TYP. or less.
- Overheat protection circuit  
Operates at 150°C or more and shuts down the output circuit.
- Mounted on 48-pin plastic WQFN (7 x 7)

### APPLICATIONS

Lens motor driving for DVC and DSC, etc.

### ORDERING INFORMATION

Part Number	Package	Marking	Packing Type
$\mu$ PD168103K9-5B4-A <sup>Note</sup>	48-pin plastic WQFN (7 x 7)	D168103	<ul style="list-style-type: none"> <li>• Tray stuffing</li> <li>• Dry pack</li> </ul>

**Note** Pb-free (This product does not contain Pb in external electrode and other parts.)

The information in this document is subject to change without notice. Before using this document, please confirm that this is the latest version.  
Not all products and/or types are available in every country. Please check with an NEC Electronics sales representative for availability and additional information.

1. BLOCK DIAGRAM

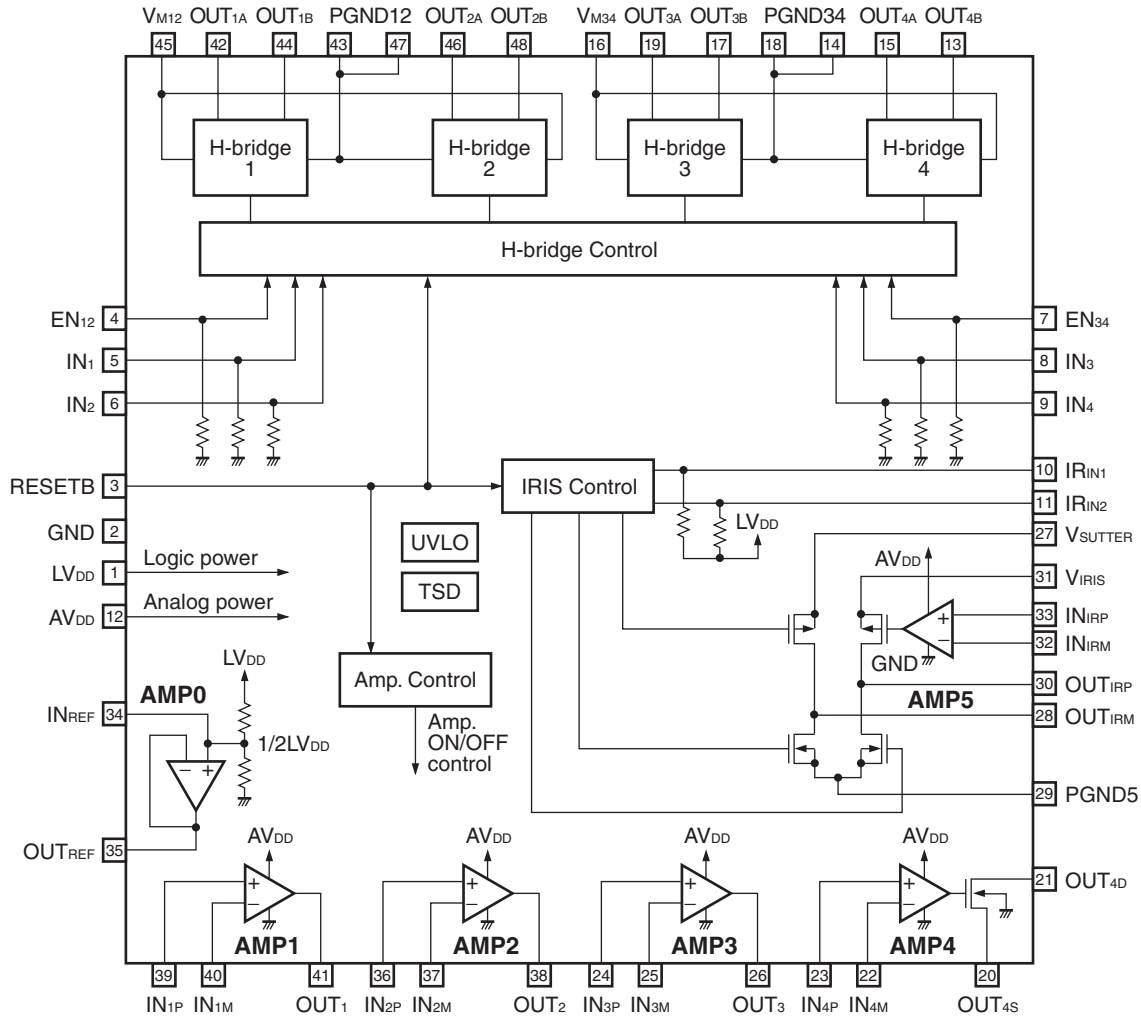

**Cautions 1.** P in pin name means plus, and M in pin name means minus.

**2.** A pull-down resistor (50 to 200 kΩ) is connected to the logic input pins (EN<sub>12</sub>, EN<sub>34</sub>, IN<sub>1</sub>, IN<sub>2</sub>, IN<sub>3</sub>, and IN<sub>4</sub>). A pull-up resistor (50 to 200 kΩ) is connected to the IR<sub>IN1</sub> and IR<sub>IN2</sub> pins.

## 2. PIN FUNCTIONS

(1/2)

Pin No.	Pin Name	I/O	Function
1	LV <sub>DD</sub>	–	Logic power supply voltage pin
2	GND	–	Logic and analog GND pin
3	RESETB	Input	Reset input pin
4	EN <sub>12</sub>	Input	ch1 and ch2 output control input pin
5	IN <sub>1</sub>	Input	ch1 input pin
6	IN <sub>2</sub>	Input	ch2 input pin
7	EN <sub>34</sub>	Input	ch3 and ch4 output control input pin
8	IN <sub>3</sub>	Input	ch3 input pin
9	IN <sub>4</sub>	Input	ch4 input pin
10	IR <sub>IN1</sub>	Input	IRIS control logic input pin 1
11	IR <sub>IN2</sub>	Input	IRIS control logic input pin 2
12	AV <sub>DD</sub>	–	Analog power supply voltage pin
13	OUT <sub>4B</sub>	Output	ch4 output pin B
14	PGND <sub>34</sub>	–	ch3 and ch4 GND pin
15	OUT <sub>4A</sub>	Output	ch4 output pin A
16	VM <sub>34</sub>	–	ch3 and ch4 power supply voltage pin
17	OUT <sub>3B</sub>	Output	ch3 output pin B
18	PGND <sub>34</sub>	–	ch3 and ch4 GND pin
19	OUT <sub>3A</sub>	Output	ch3 output pin A
20	OUT <sub>4S</sub>	Output	Amplifier 4 (AMP4) source output pin (source)
21	OUT <sub>4D</sub>	Output	Amplifier 4 (AMP4) drain output pin (sink)
22	IN <sub>4M</sub>	Input	Amplifier 4 (AMP4) minus input pin
23	IN <sub>4P</sub>	Input	Amplifier 4 (AMP4) plus input pin
24	IN <sub>3P</sub>	Input	Amplifier 3 (AMP3) plus input pin
25	IN <sub>3M</sub>	Input	Amplifier 3 (AMP3) minus input pin
26	OUT <sub>3</sub>	Output	Amplifier 3 (AMP3) output pin
27	V <sub>SHUTTER</sub>	–	Shutter (ON/OFF) power supply voltage pin
28	OUT <sub>IRM</sub>	Output	IRIS minus output pin
29	PGND <sub>5</sub>	–	IRIS and shutter GND pin
30	OUT <sub>IRP</sub>	Output	IRIS plus output pin
31	V <sub>IRIS</sub>	–	IRIS (linear) power supply voltage pin
32	IN <sub>IRM</sub>	Input	IRIS linear control (AMP5) minus input pin
33	IN <sub>IRP</sub>	Input	IRIS linear control (AMP5) plus input pin
34	IN <sub>REF</sub>	Input	1/2AV <sub>DD</sub> amplifier (AMP0) input pin (for capacitor connection)

(2/2)

Pin No.	Pin Name	I/O	Function
35	OUT <sub>REF</sub>	Output	1/2AV <sub>DD</sub> amplifier (AMP0) output pin
36	IN <sub>2P</sub>	Input	Amplifier 2 (AMP2) plus input pin
37	IN <sub>2M</sub>	Input	Amplifier 2 (AMP2) minus input pin
38	OUT <sub>2</sub>	Output	Amplifier 2 (AMP2) output pin
39	IN <sub>1P</sub>	Input	Amplifier 1 (AMP1) plus input pin
40	IN <sub>1M</sub>	Input	Amplifier 1 (AMP1) minus input pin
41	OUT <sub>1</sub>	Output	Amplifier 1 (AMP1) output pin
42	OUT <sub>1A</sub>	Output	ch1 output pin A
43	PGND12	–	ch1 and ch2 GND pin
44	OUT <sub>1B</sub>	Output	ch1 output pin B
45	V <sub>M12</sub>	–	ch1 and ch2 power supply voltage pin
46	OUT <sub>2A</sub>	Output	ch2 output pin A
47	PGND12	–	ch1 and ch2 GND pin
48	OUT <sub>2B</sub>	Output	ch2 output pin B

### 3. FUNCTION OPERATION TABLE

#### 3.1 Reset Function

The internal circuit is shut off and the circuit current is kept to 1 μA MAX. when the RESETB pin is made L (reset status). In this status, the output pin goes into a Hi-Z (High impedance) state. Set the RESETB pin H for normal usage.

**Remark** H: High level, L: Low level

#### 3.2 Stepping Motor Driving Block

Table 3-1. I/O Truth Table of the Stepping Motor Driving Block

EN <sub>12</sub> , EN <sub>34</sub>	IN <sub>1</sub> , IN <sub>2</sub> , IN <sub>3</sub> , IN <sub>4</sub>	OUT <sub>1A</sub> , OUT <sub>2A</sub> , OUT <sub>3A</sub> , OUT <sub>4A</sub>	OUT <sub>1B</sub> , OUT <sub>2B</sub> , OUT <sub>3B</sub> , OUT <sub>4B</sub>
H	L	H	L
	H	L	H
L	L	Hi-Z	Hi-Z
	H	Hi-Z	Hi-Z

3.3 IRIS Motor Driving Block

Table 3-2. I/O Truth Table of the IRIS Driving Block

IR <sub>IN1</sub>	IR <sub>IN2</sub>	Operation Mode	Output State of H-bridge				OUT <sub>IRP</sub>	OUT <sub>IRM</sub>
			Q1	Q2	Q3	Q4		
L	L	Normal operation (Amp. control)	ON	OFF	OFF	ON (Linear)	Linear	Linear
L	H	Shutter	OFF	ON	ON	OFF	L	H
H	L	IRIS open	ON	OFF	OFF	ON	H	L
H	H	Output all OFF	OFF	OFF	OFF	OFF	Hi-Z	Hi-Z

Figure 3-1. Description of the Operation Figure of the IRIS Motor Driving Block

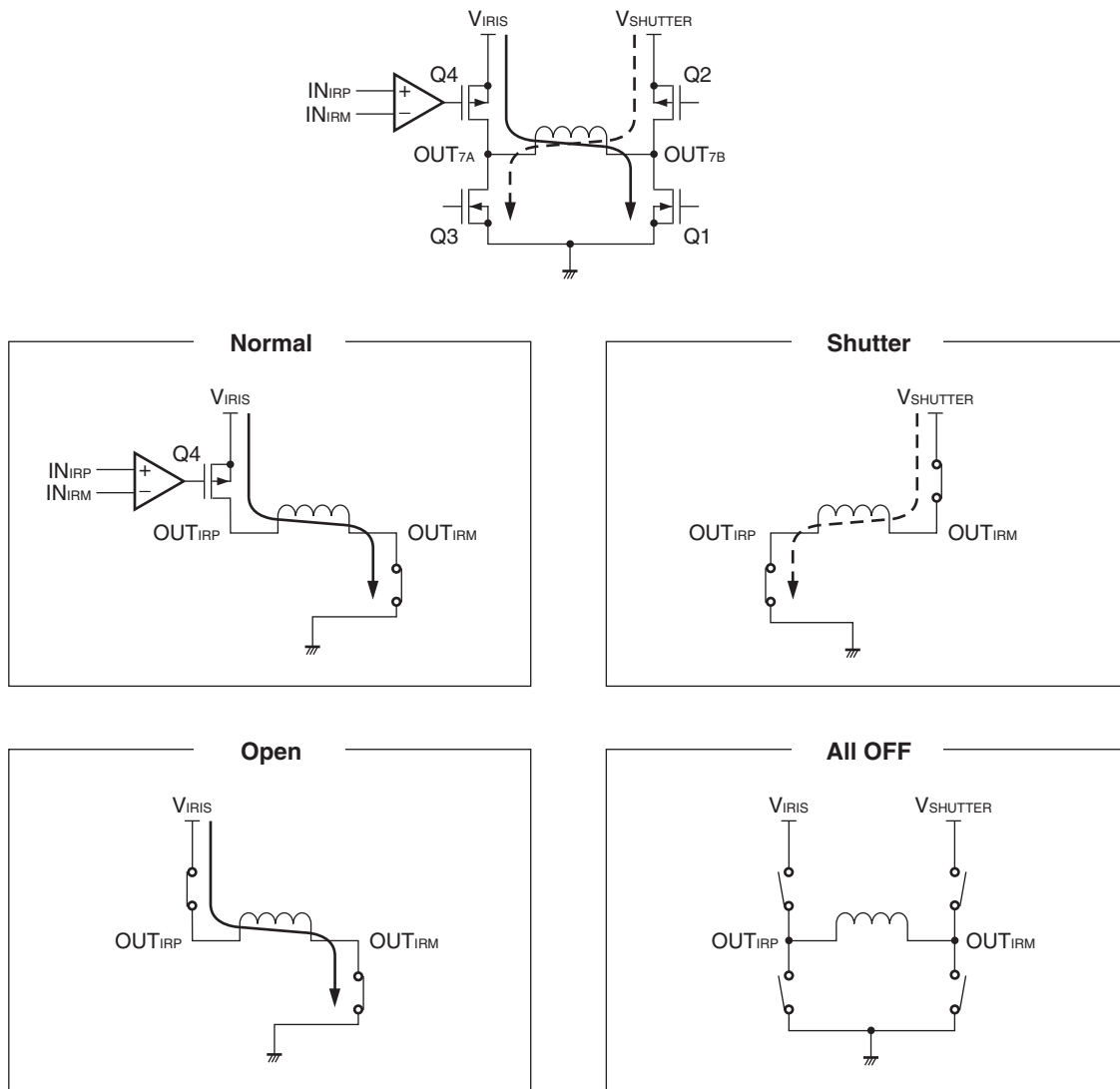

## 4. FUNCTIONAL DEPLOYMENT

### 4.1 Undervoltage Lockout (UVLO) Circuit

This function is to forcibly stop the operation of the  $\mu$  PD168103 to prevent malfunctioning if  $LV_{DD}$  drops.

When UVLO operates, the driver output and amplifier circuit are the OFF status.

The UVLO circuit detects a voltage drop if  $LV_{DD}$  drops to 1.7 V TYP. in the non-reset status ( $RESETB = H$ ). In the reset status ( $RESETB = L$ ), it detects a voltage drop if  $LV_{DD}$  drops to 0.6 V TYP. This circuit may not operate if the  $LV_{DD}$  voltage abruptly drops for just a few  $\mu s$ .

### 4.2 Overheat Protection (TSD) Circuit

This function is to forcibly stop the operation of the driver output to protect it from destruction due to overheating if the chip temperature of the  $\mu$  PD168103 rises.

The overheat protection circuit operates when the chip temperature rises to 150°C or more. When overheat is detected, the driver output is stopped.

When  $RESETB = L$  (the reset status) or when UVLO is detected, the overheat protection circuit does not operate.

### 4.3 Power Up Sequence

The  $\mu$  PD168103 has a circuit that prevents current from flowing into the  $V_M$ ,  $V_{SHUTTER}$  and  $V_{IRIS}$  pins (from the next, these are written as the motor power supply pins) when  $LV_{DD} = 0 V$  or  $AV_{DD} = 0 V$ . Therefore, the current that flows into the motor power supply pins are cut off when  $LV_{DD} = 0 V$ .

Because the  $LV_{DD}$  pin voltage, the  $AV_{DD}$  pin voltage and the motor power supply pins voltage are monitored, a current of 1  $\mu A$  TYP. flows into each one of the motor power supply pins when  $LV_{DD}$  is applied.

**5. NOTE ON CORRECT USE**

**5.1 Pin Processing of Unused Circuit**

The input/output pins of an unused circuit must be processed as specified below.

A pull-down or pull-up resistor is connected inside to the logic input pins. Connect the input pins to the GND or LV<sub>DD</sub> (IN<sub>IR1</sub> and IN<sub>IR2</sub>) potential when they are not used.

A pull-down resistor is not connected to the RESETB pin. Be sure to fix the RESETB pin to the LV<sub>DD</sub> or GND potential when it is used.

**5.2 OUT<sub>4s</sub> pin**

Keep the voltage in the OUT<sub>4s</sub> pin to 2 V or less.

If an application circuit like the one shown below is used, the input voltage range of the amplifier is also 2 V or less.

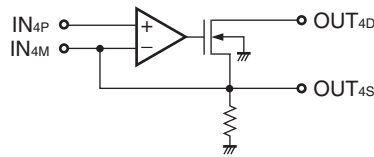



6. ELECTRICAL SPECIFICATIONS

**Absolute Maximum Ratings (T<sub>A</sub> = 25°C, glass epoxy board of 100 mm x 100 mm x 1 mm with copper foil area of 15%)**

Parameter	Symbol	Condition	Rating	Unit
Power supply voltage	LV <sub>DD</sub>	Control block	-0.5 to +6.0	V
	AV <sub>DD</sub>	Analog block	-0.5 to +6.0	V
	V <sub>M12</sub> , V <sub>M34</sub>	Stepping motor block	-0.5 to +6.0	V
	V <sub>SHUTTER</sub> , V <sub>IRIS</sub>	IRIS block	-0.5 to +6.0	V
Input voltage <sup>Note1</sup>	V <sub>IN</sub>		-0.5 to LV <sub>DD</sub> + 0.5	V
Output pin voltage 1	V <sub>OUT1</sub>	Motor block	6.2	V
Output pin voltage 2	V <sub>OUT2</sub>	Amplifier block	-0.5 to AV <sub>DD</sub> + 0.5	V
DC output current	I <sub>D1(DC)</sub>	DC (stepping motor)	±0.3	A/ch
	I <sub>D2(DC)</sub>	DC (IRIS)	±0.2	A/ch
Instantaneous output current	I <sub>D(pulse)</sub>	PW < 10 ms, Duty Cycle ≤ 20%	±0.7	A/ch
Power consumption	P <sub>T</sub>		1.0	W
Peak junction temperature <sup>Note2</sup>	T <sub>ch(MAX)</sub>		150	°C
Storage temperature	T <sub>stg</sub>		-55 to +150	°C

**Notes 1.** Keep V<sub>IN</sub> to less than 6 V.

- The overheat protection circuit operates at T<sub>ch</sub> > 150°C. When overheat is detected, all the circuits are stopped. The overheat protection circuit does not operate at reset or on detection of ULVO.

**Caution** Product quality may suffer if the absolute maximum rating is exceeded even momentarily for any parameter. That is, the absolute maximum ratings are rated values at which the product is on the verge of suffering physical damage, and therefore the product must be used under conditions that ensure that the absolute maximum ratings are not exceeded.

**Recommended Operating Conditions (T<sub>A</sub> = 25°C, glass epoxy board of 100 mm x 100 mm x 1 mm with copper foil area of 15%)**

Parameter	Symbol	Condition	MIN.	TYP.	MAX.	Unit
Power supply voltage	LV <sub>DD</sub>	Control block	2.7		3.6	V
	AV <sub>DD</sub>	Analog block	4.5		5.5	V
	V <sub>M12</sub> , V <sub>M34</sub>	Stepping motor block	2.7		5.5	V
	V <sub>SHUTTER</sub> , V <sub>IRIS</sub>	IRIS block	2.7		5.5	V
Input voltage	V <sub>IN</sub>		0		V <sub>DD</sub>	V
DC output current	I <sub>D1(DC)</sub>	DC (stepping motor, when 2 chs are driven at same time)	-0.2		+0.2	A/ch
	I <sub>D2(DC)</sub>	DC (IRIS), maximum current when the shutter operates	-0.1		+0.1	A/ch
Amplifier output current	I <sub>OUT_AMP1</sub>	AMP1 to AMP3	-5		+5	mA/ch
Amplifier output sink current	I <sub>OUT_AMP2</sub>	AMP4	0		+5	mA
Logic input frequency	f <sub>IN</sub>				100	kHz
Operating temperature range	T <sub>A</sub>		-10		70	°C

**Caution** Design each output current so that the junction temperature does not exceed 150°C.

Electrical Characteristics (Unless otherwise specified,  $T_A = 25^\circ\text{C}$ ,  $LV_{DD} = 3.0\text{ V}$ ,  $AV_{DD} = 5.0\text{ V}$ ,  $V_M = V_{SHUTTER} = V_{IRIS} = 5.0\text{ V}$ )

Overall and H-bridge block (stepping motor)

Parameter	Symbol	Condition	MIN.	TYP.	MAX.	Unit
LV <sub>DD</sub> pin current in standby mode	ILV <sub>DD</sub> (STB)	RESETB = 0 V			1.0	μA
AV <sub>DD</sub> pin current in standby mode	IAV <sub>DD</sub> (STB)	RESETB = 0 V			1.0	μA
V <sub>M</sub> pin current in standby mode	IV <sub>M</sub> (STB)	RESETB = 0 V			1.0	μA
LV <sub>DD</sub> pin current in during operation	ID <sub>D</sub> (ACT)	RESETB = LV <sub>DD</sub>			2.0	mA
High-level input current	I <sub>IH</sub>	V <sub>IN</sub> = LV <sub>DD</sub>			60	μA
Low-level input current	I <sub>IL</sub>	V <sub>IN</sub> = 0 V	-1.0			μA
Input pull-down resistance	R <sub>IND</sub>		50		200	kΩ
High-level input voltage	V <sub>IH</sub>		0.7 x V <sub>DD</sub>			V
Low-level input voltage	V <sub>IL</sub>				0.3 x V <sub>DD</sub>	V
H-bridge on-state resistance	R <sub>on</sub>	I <sub>M</sub> = 0.2 A, sum of upper and lower stages		2.0	3.0	Ω
Output leakage current <sup>Note 1</sup>	I <sub>M(off)</sub>	Per V <sub>M</sub> pin, All control pins: low level			1.0	μA
Low-voltage detection voltage <sup>Note 2</sup>	V <sub>DDS1</sub>	RESETB = H		1.7	2.5	V
Output turn-on time	t <sub>on</sub>	R <sub>L</sub> = 20 Ω		0.5	1.0	μs
Output turn-off time	t <sub>off</sub>			0.1	0.4	μs
Output rise time	t <sub>r</sub>		0.05	0.2	0.4	μs
Output fall time	t <sub>f</sub>			50	100	ns

Notes 1. μ PD168103 has a circuit that prevents current from flowing into the V<sub>M</sub> pin when LV<sub>DD</sub> = 0 V.

2. Unlike normal operations, after a reset the detection voltage becomes 0.6 V TYP.

Figure 6–1. Switching Characteristic Waveform of the Stepping Motor Driving Block

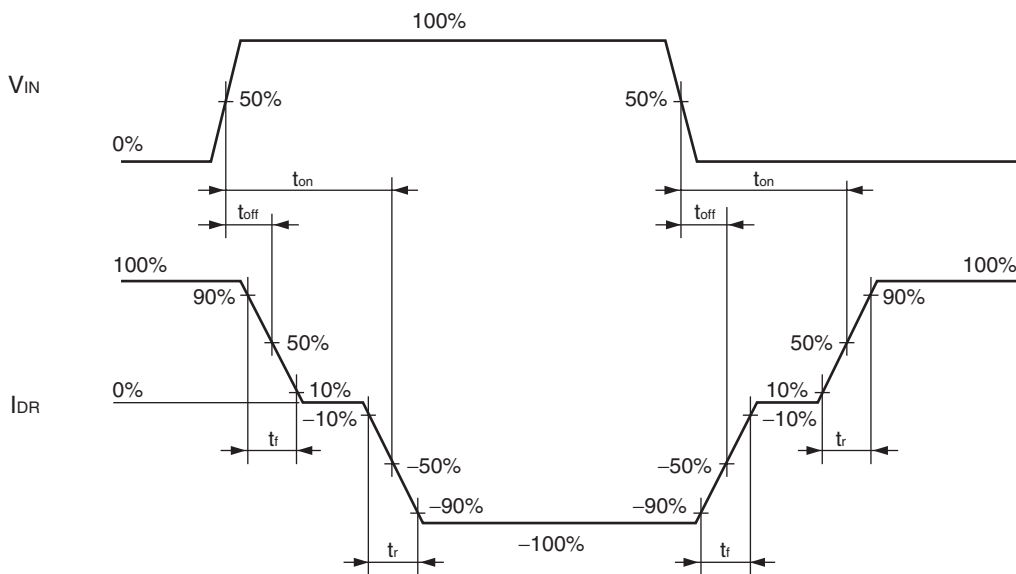

**H-bridge block (IRIS motor)**

Parameter	Symbol	Condition	MIN.	TYP.	MAX.	Unit
V <sub>IRIS</sub> pin current in standby mode	I <sub>IRIS(STB)</sub>	RESETB = 0 V			1.0	μA
V <sub>SHUTTER</sub> pin current in standby mode	I <sub>SHUTTER(STB)</sub>	RESETB = 0 V			1.0	μA
High-level input current	I <sub>IH</sub>	V <sub>IN</sub> = LV <sub>DD</sub>			1.0	μA
Low-level input current	I <sub>IL</sub>	V <sub>IN</sub> = 0 V	-60			μA
Input pull-up resistance	R <sub>IND</sub>		50		200	kΩ
High-level input voltage	V <sub>IH</sub>		0.7 x V <sub>DD</sub>			V
Low-level input voltage	V <sub>IL</sub>				0.3 x V <sub>DD</sub>	V
H-bridge on-state resistance	R <sub>on1</sub>	R <sub>L</sub> = 50 Ω, sum of upper and lower stages		2.5	3.5	Ω
Output turn-on time	t <sub>onH1</sub>	When linear driving, R <sub>L</sub> = 50 Ω	0.01	25	35	μs
	t <sub>onH2</sub>		0.01	1.0	2.0	μs
Output turn-off time	t <sub>offH</sub>		0.01	1.0	2.0	μs
Output rise time	t <sub>rH</sub>			60		ns
Output fall time	t <sub>fH</sub>			80		ns
Control amplifier offset voltage	V <sub>IO</sub>	AMP5		±5	±7.5	mV

**Figure 6–2. Switching Characteristic Waveform of the IRIS Motor Driving Block**

at I<sub>RIN1</sub> = L

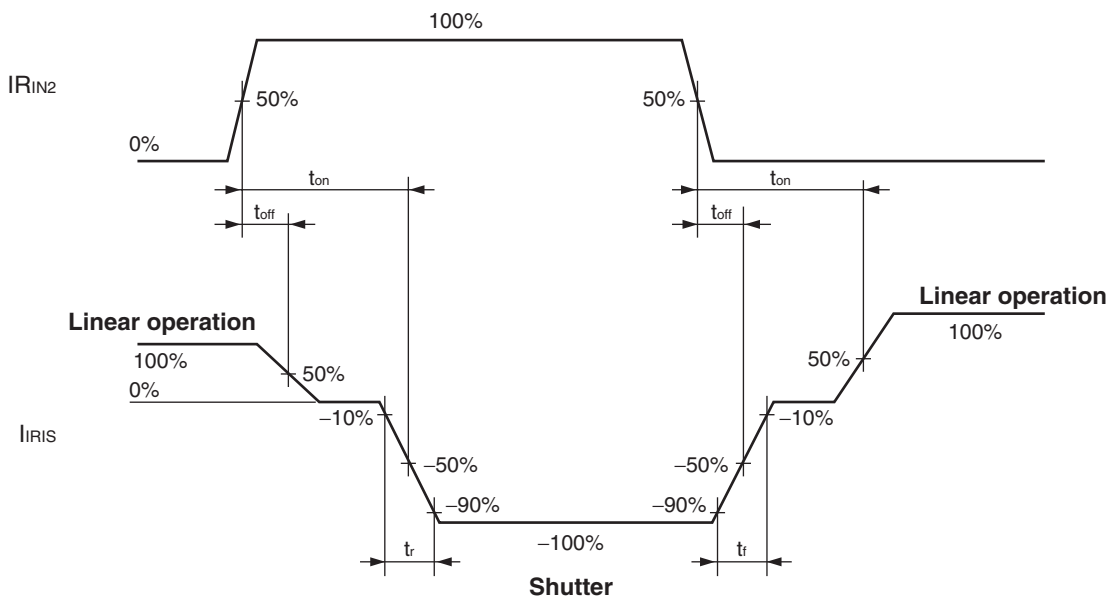

**Operational amplifier block**

Parameter	Symbol	Condition	MIN.	TYP.	MAX.	Unit
AV <sub>DD</sub> pin current in during operation	IA <sub>DD</sub>	Output open			3.0	mA
Input offset voltage 1	V <sub>IO1</sub>	AMP1 to AMP3, AMP5		±3	±5	mV
Input offset voltage 2	V <sub>IO2</sub>	AMP4		±5	±7	mV
Common mode input voltage range 1	V <sub>ICM1</sub>	AMP1 to AMP3, AMP5	0		AV <sub>DD</sub> - 1.5	V
Common mode input voltage range 2	V <sub>ICM2</sub>	AMP4	0		AV <sub>DD</sub> - 2.0	V
High-level output voltage	V <sub>OH</sub>	AMP1 to AMP3, when I <sub>OUT</sub> = +2 mA	AV <sub>DD</sub> - 0.2			V
Low-level output voltage	V <sub>OL</sub>	AMP1 to AMP3, when I <sub>OUT</sub> = -2 mA			0.2	V
Large amplitude voltage gain	A <sub>V</sub>	AMP1 to AMP3, DC	80			dB
Slew-rate	SR	AMP1 to AMP3, A <sub>v</sub> = 1 dB, R <sub>L</sub> ≥ 10 kΩ		0.5		V/μs
1/2 AV <sub>DD</sub> output voltage accuracy	V <sub>O</sub>	AMP0, I <sub>OUT</sub> = ±100 μA	2.4	2.5	2.6	V

7. TYPICAL CHARACTERISTICS (Unless otherwise specified,  $T_A = 25^\circ\text{C}$ ,  $LV_{DD} = 3.0\text{ V}$ ,  $AV_{DD} = V_M = V_{SHUTTER} = V_{IRIS} = 5.0\text{ V}$ )

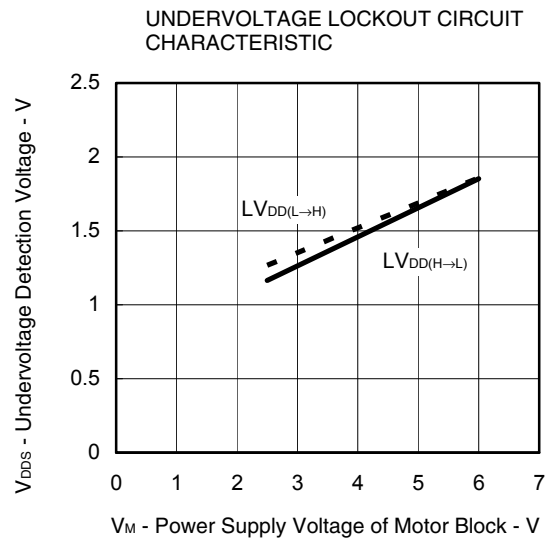
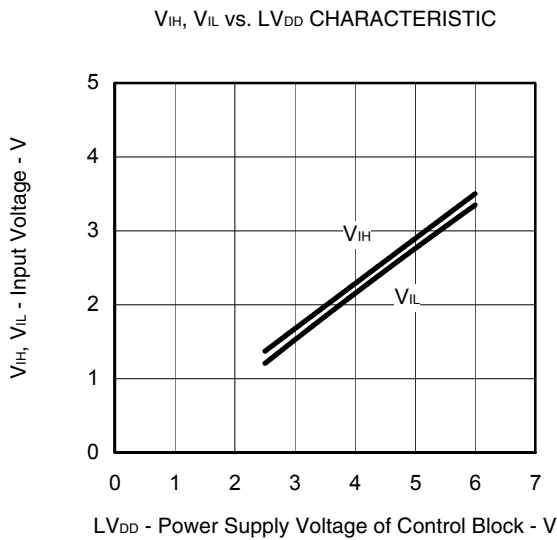
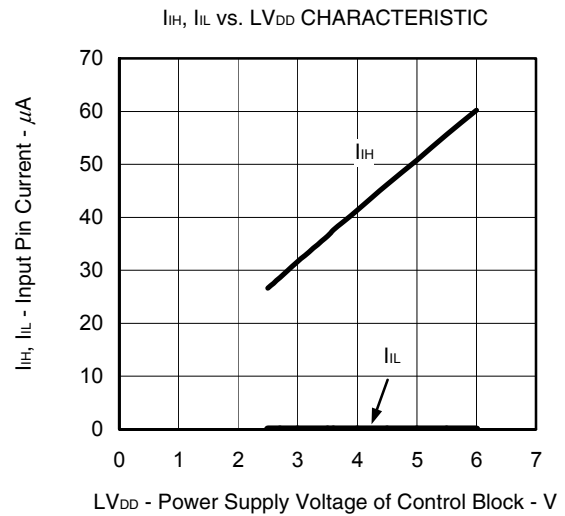
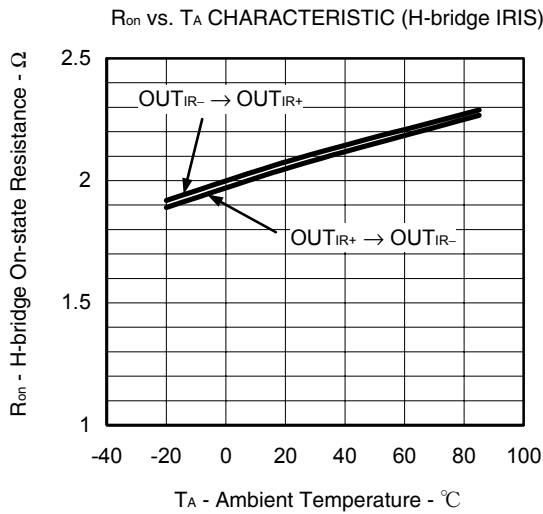
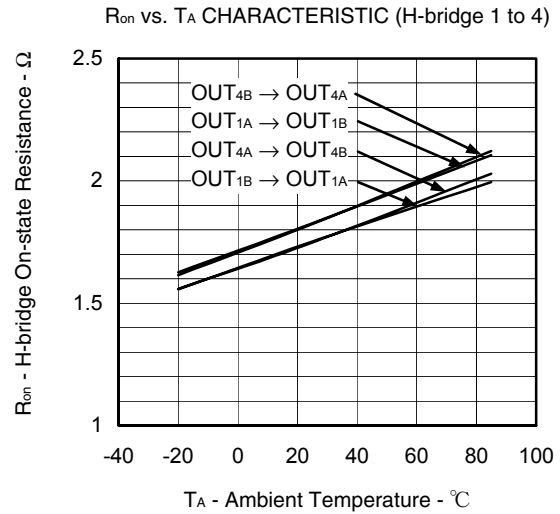
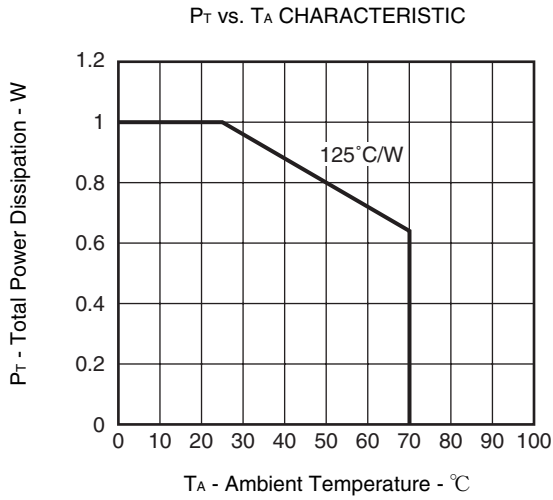

R<sub>on</sub> vs. V<sub>M</sub> CHARACTERISTIC

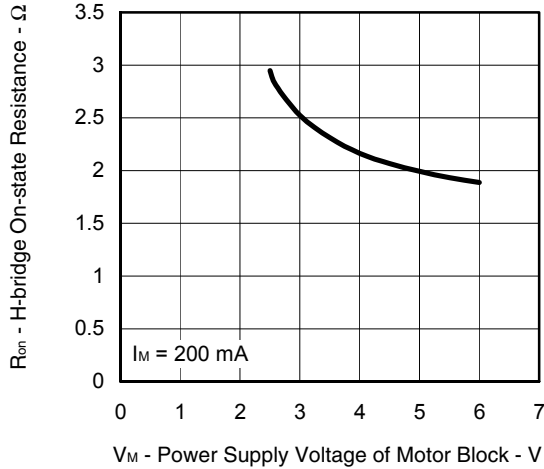

R<sub>on</sub> vs. V<sub>IRIS</sub>, V<sub>SHUTTER</sub> CHARACTERISTIC

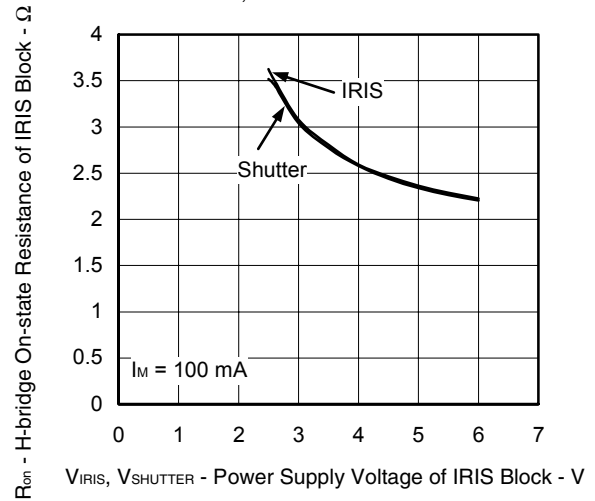

T<sub>ONH</sub>, T<sub>OFFH</sub> vs. V<sub>M</sub> CHARACTERISTIC

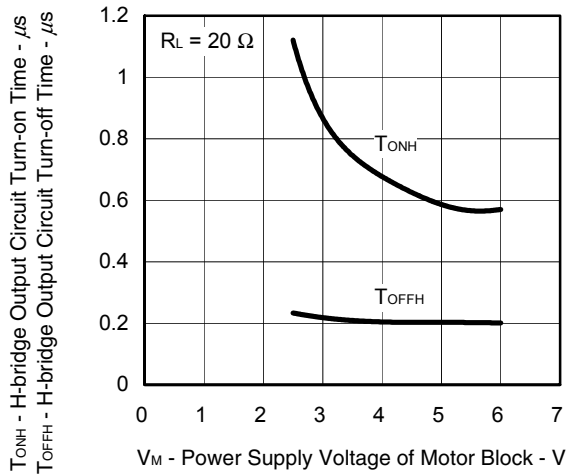

T<sub>r</sub>, T<sub>f</sub> vs. V<sub>IRIS</sub>, V<sub>SHUTTER</sub> CHARACTERISTIC (when full ON)

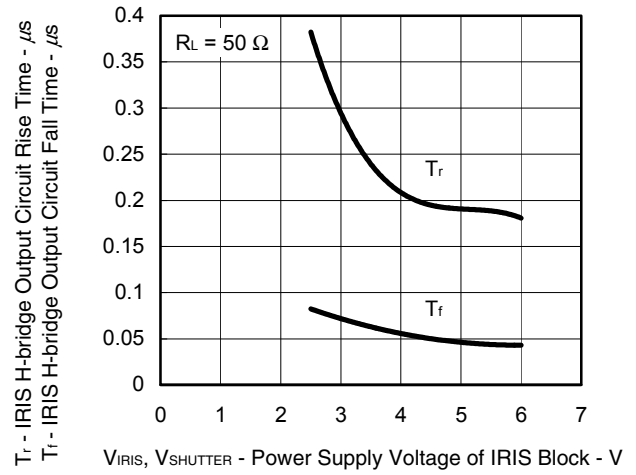

T<sub>r</sub>, T<sub>f</sub> vs. V<sub>M</sub> CHARACTERISTIC

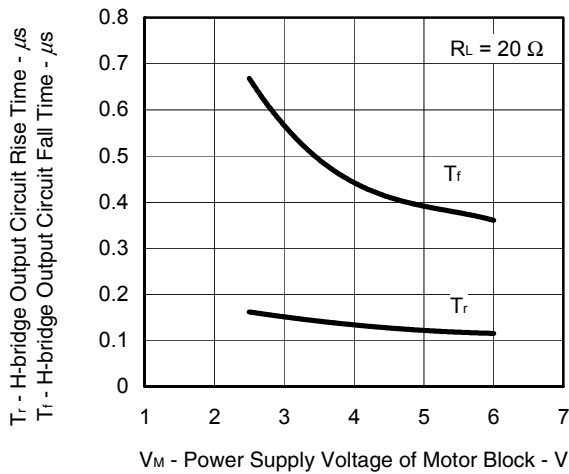

T<sub>ONH1</sub>, T<sub>OFFH</sub> vs. V<sub>IRIS</sub>, V<sub>SHUTTER</sub> CHARACTERISTIC (when Linear)

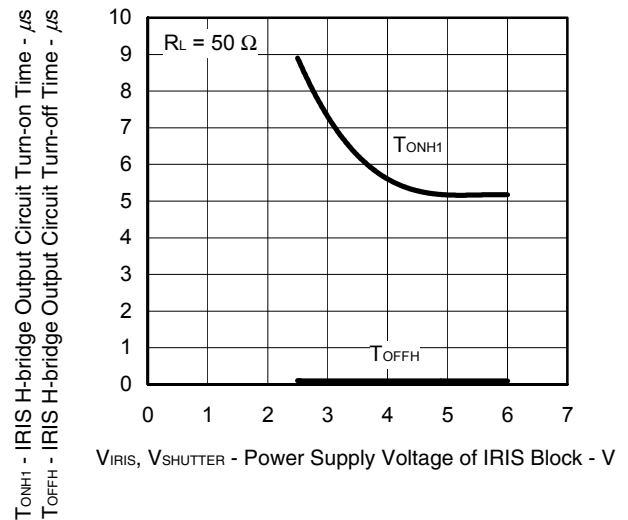

$T_r, T_f$  vs.  $V_{IRIS}, V_{SHUTTER}$  CHARACTERISTIC  
(when Linear)

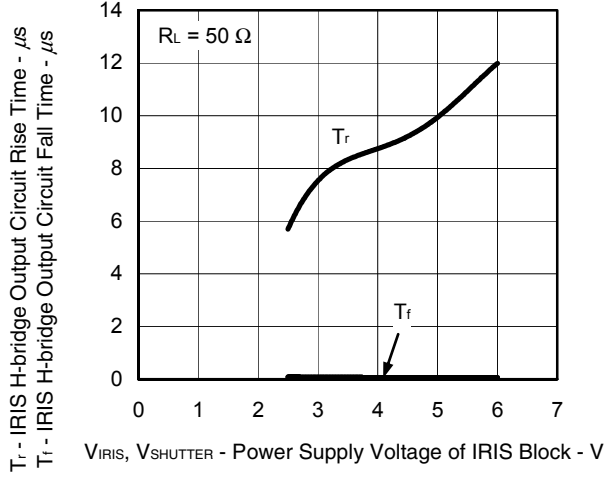

$T_{ONH1}, T_{OFFH}$  vs.  $V_{IRIS}, V_{SHUTTER}$  CHARACTERISTIC  
(when full ON)

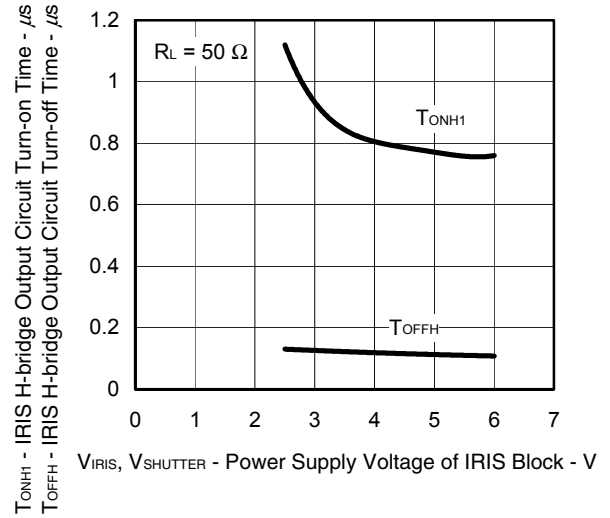

$I_M$  vs.  $V_M$  CHARACTERISTIC

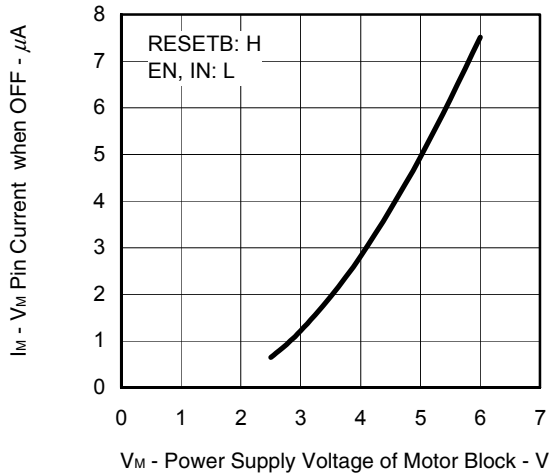

$I_{LVDD}$  vs.  $V_{LVDD}$  CHARACTERISTIC

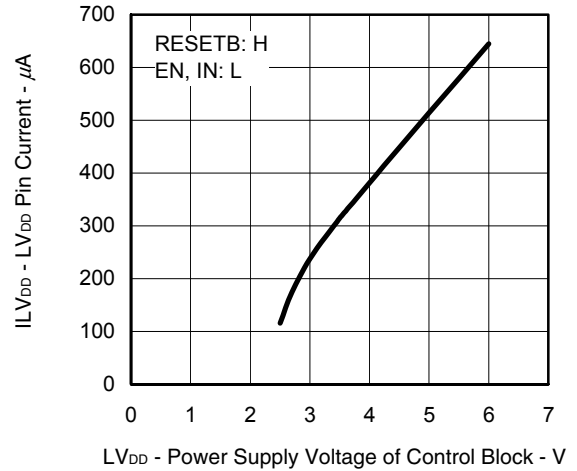

8. STANDARD CONNECTION EXAMPLE

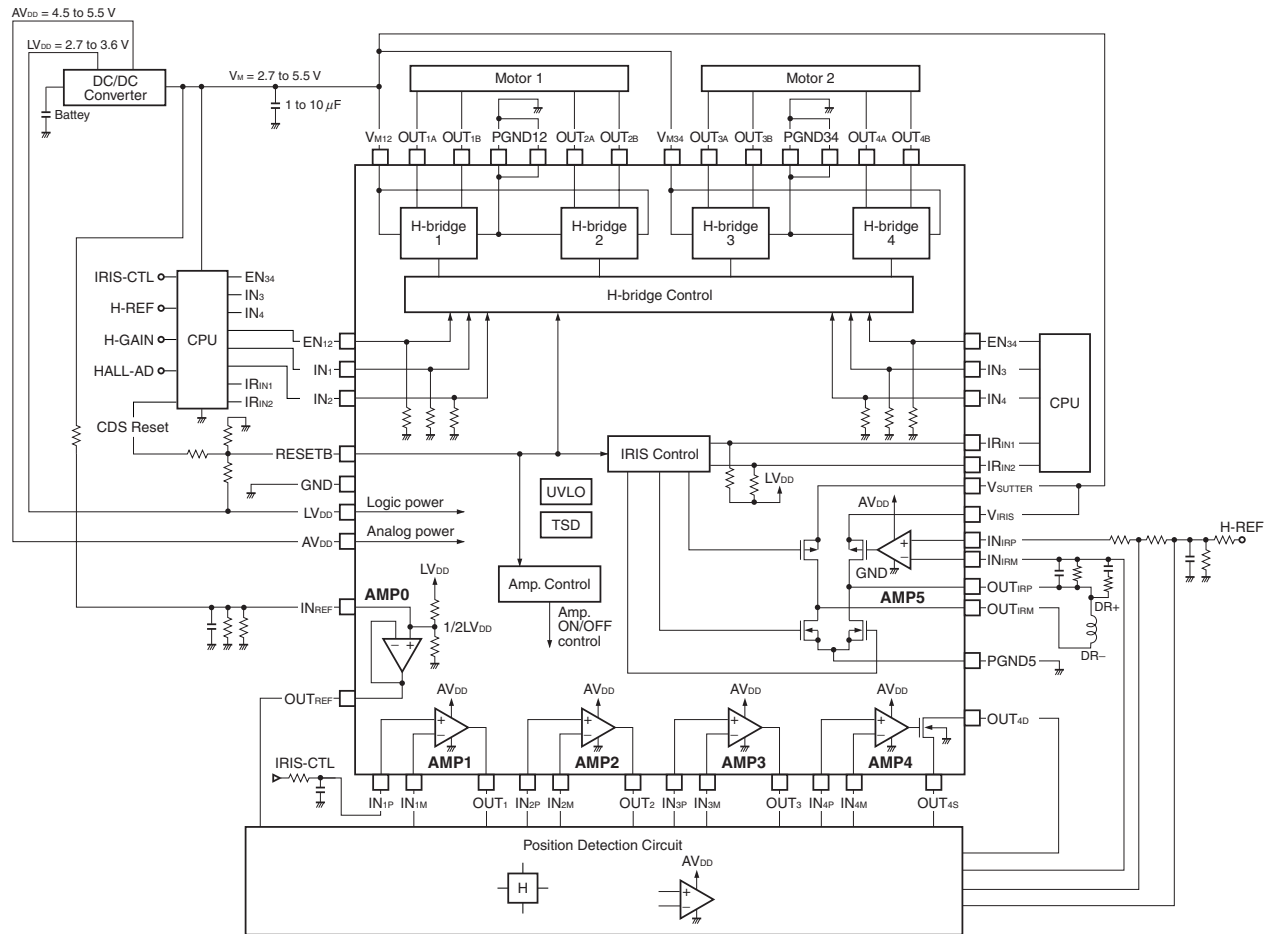



9. PACKAGE DRAWING

48-PIN PLASTIC WQFN (7x7)

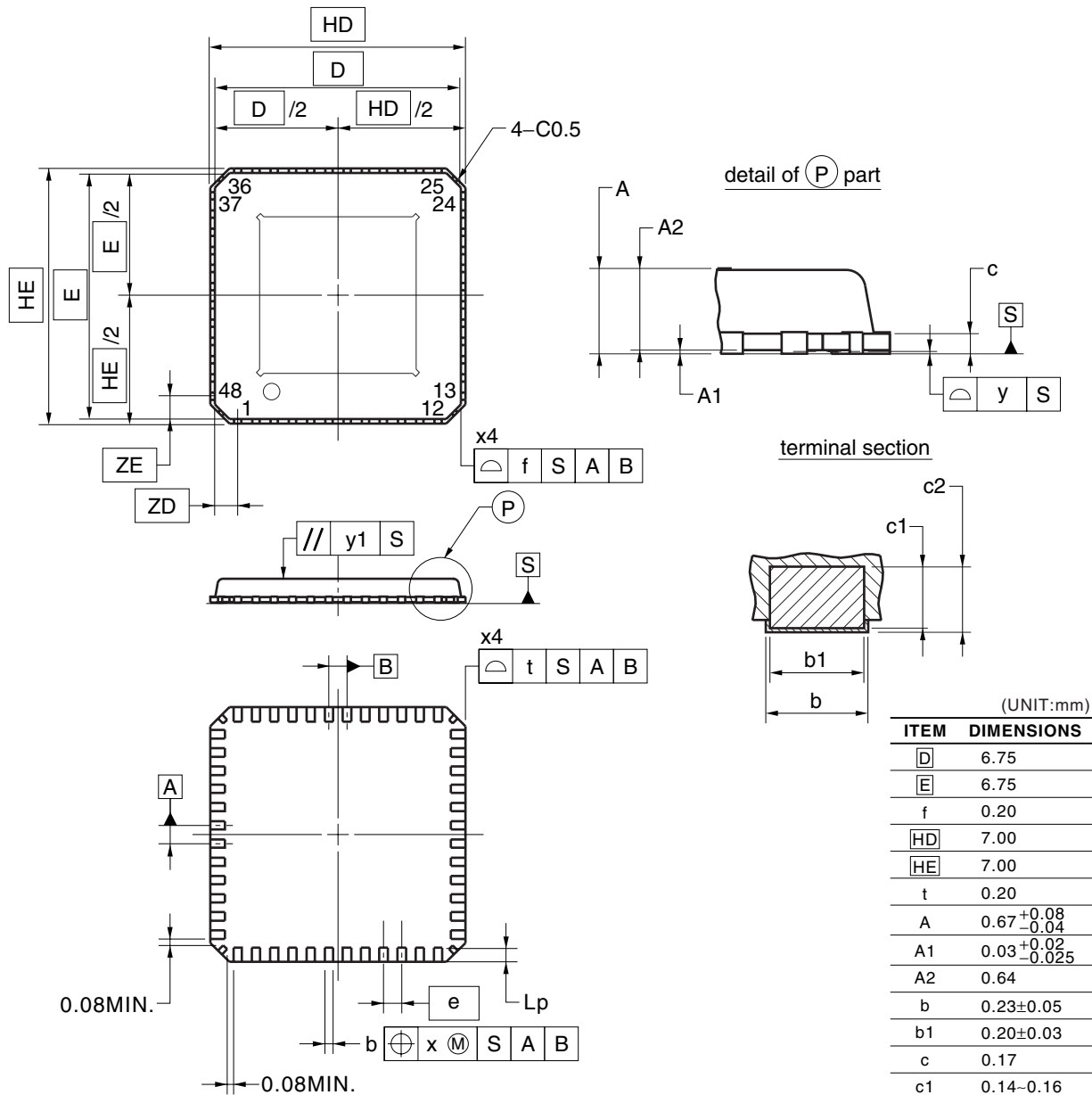

NOTES

- \*1 "t" AND "f" EXCLUDES MOLD FLASH
- \*2 ALTHOUGH THERE ARE 4 TERMINALS IN THE CORNER PART OF A PACKAGE, THESE TERMINALS ARE NOT DESIGNED FOR INTERCONNECTION, BUT FOR MANUFACTURING PROCESS OF THE PACKAGE, THEREFOR DO NOT INTEND TO SOLDER THESE 4 TERMINALS. SOLDERABILITY OF THE 4 TERMINALS ARE NOT GUARANTEED.

(UNIT:mm)

ITEM	DIMENSIONS
D	6.75
E	6.75
f	0.20
HD	7.00
HE	7.00
t	0.20
A	0.67 <sup>+0.08</sup> <sub>-0.04</sub>
A1	0.03 <sup>+0.02</sup> <sub>-0.025</sub>
A2	0.64
b	0.23±0.05
b1	0.20±0.03
c	0.17
c1	0.14-0.16
c2	0.14-0.20
e	0.50
Lp	0.40±0.10
x	0.05
y	0.08
y1	0.10
ZD	0.625
ZE	0.625

P48K9-50-5B4-1

**10. RECOMMENDED SOLDERING CONDITIONS**

The μ PD168103 should be soldered and mounted under the following recommended conditions.

For soldering methods and conditions other than those recommended below, contact an NEC Electronics sales representative.

For technical information, see the following website.

**Semiconductor Device Mount Manual (<http://www.necel.com/pkg/en/mount/index.html>)**

**Type of Surface Mount Device**

μ PD168103K9-5B4-A<sup>Note1</sup>: 48-pin plastic WQFN (7 x 7)

Process	Conditions	Symbol
Infrared reflow	Package peak temperature: 260°C, Time: 60 seconds MAX. (at 220°C or higher) , Count: Three times or less, Exposure limit: 3 days <sup>Note2</sup> (after that, prebake at 125°C for 10 hours) , Flux: Rosin flux with low chlorine (0.2 Wt% or below) recommended. <Precaution> Products other than in heat-resistant trays (such as those packaged in a magazine, taping, or non-thermal-resistant tray) cannot be baked in their package.	IR60-103-3

**Notes 1.** Pb-free (This product does not contain Pb in external electrode and other parts.)

**2.** After opening the dry pack, store it a 25°C or less and 65% RH or less for the allowable storage period.

**Caution Do not use different soldering methods together (except for partial heating).**

## NOTES FOR CMOS DEVICES

**① VOLTAGE APPLICATION WAVEFORM AT INPUT PIN**

Waveform distortion due to input noise or a reflected wave may cause malfunction. If the input of the CMOS device stays in the area between  $V_{IL}$  (MAX) and  $V_{IH}$  (MIN) due to noise, etc., the device may malfunction. Take care to prevent chattering noise from entering the device when the input level is fixed, and also in the transition period when the input level passes through the area between  $V_{IL}$  (MAX) and  $V_{IH}$  (MIN).

**② HANDLING OF UNUSED INPUT PINS**

Unconnected CMOS device inputs can be cause of malfunction. If an input pin is unconnected, it is possible that an internal input level may be generated due to noise, etc., causing malfunction. CMOS devices behave differently than Bipolar or NMOS devices. Input levels of CMOS devices must be fixed high or low by using pull-up or pull-down circuitry. Each unused pin should be connected to  $V_{DD}$  or GND via a resistor if there is a possibility that it will be an output pin. All handling related to unused pins must be judged separately for each device and according to related specifications governing the device.

**③ PRECAUTION AGAINST ESD**

A strong electric field, when exposed to a MOS device, can cause destruction of the gate oxide and ultimately degrade the device operation. Steps must be taken to stop generation of static electricity as much as possible, and quickly dissipate it when it has occurred. Environmental control must be adequate. When it is dry, a humidifier should be used. It is recommended to avoid using insulators that easily build up static electricity. Semiconductor devices must be stored and transported in an anti-static container, static shielding bag or conductive material. All test and measurement tools including work benches and floors should be grounded. The operator should be grounded using a wrist strap. Semiconductor devices must not be touched with bare hands. Similar precautions need to be taken for PW boards with mounted semiconductor devices.

**④ STATUS BEFORE INITIALIZATION**

Power-on does not necessarily define the initial status of a MOS device. Immediately after the power source is turned ON, devices with reset functions have not yet been initialized. Hence, power-on does not guarantee output pin levels, I/O settings or contents of registers. A device is not initialized until the reset signal is received. A reset operation must be executed immediately after power-on for devices with reset functions.

**⑤ POWER ON/OFF SEQUENCE**

In the case of a device that uses different power supplies for the internal operation and external interface, as a rule, switch on the external power supply after switching on the internal power supply. When switching the power supply off, as a rule, switch off the external power supply and then the internal power supply. Use of the reverse power on/off sequences may result in the application of an overvoltage to the internal elements of the device, causing malfunction and degradation of internal elements due to the passage of an abnormal current.

The correct power on/off sequence must be judged separately for each device and according to related specifications governing the device.

**⑥ INPUT OF SIGNAL DURING POWER OFF STATE**

Do not input signals or an I/O pull-up power supply while the device is not powered. The current injection that results from input of such a signal or I/O pull-up power supply may cause malfunction and the abnormal current that passes in the device at this time may cause degradation of internal elements. Input of signals during the power off state must be judged separately for each device and according to related specifications governing the device.

**Reference Documents****NEC Semiconductor Device Reliability/Quality Control System (C10983E)****Quality Grades On NEC Semiconductor Devices (C11531E)**

- **The information in this document is current as of February, 2005. The information is subject to change without notice. For actual design-in, refer to the latest publications of NEC Electronics data sheets or data books, etc., for the most up-to-date specifications of NEC Electronics products. Not all products and/or types are available in every country. Please check with an NEC Electronics sales representative for availability and additional information.**
- No part of this document may be copied or reproduced in any form or by any means without the prior written consent of NEC Electronics. NEC Electronics assumes no responsibility for any errors that may appear in this document.
- NEC Electronics does not assume any liability for infringement of patents, copyrights or other intellectual property rights of third parties by or arising from the use of NEC Electronics products listed in this document or any other liability arising from the use of such products. No license, express, implied or otherwise, is granted under any patents, copyrights or other intellectual property rights of NEC Electronics or others.
- Descriptions of circuits, software and other related information in this document are provided for illustrative purposes in semiconductor product operation and application examples. The incorporation of these circuits, software and information in the design of a customer's equipment shall be done under the full responsibility of the customer. NEC Electronics assumes no responsibility for any losses incurred by customers or third parties arising from the use of these circuits, software and information.
- While NEC Electronics endeavors to enhance the quality, reliability and safety of NEC Electronics products, customers agree and acknowledge that the possibility of defects thereof cannot be eliminated entirely. To minimize risks of damage to property or injury (including death) to persons arising from defects in NEC Electronics products, customers must incorporate sufficient safety measures in their design, such as redundancy, fire-containment and anti-failure features.
- NEC Electronics products are classified into the following three quality grades: "Standard", "Special" and "Specific".

The "Specific" quality grade applies only to NEC Electronics products developed based on a customer-designated "quality assurance program" for a specific application. The recommended applications of an NEC Electronics product depend on its quality grade, as indicated below. Customers must check the quality grade of each NEC Electronics product before using it in a particular application.

"Standard": Computers, office equipment, communications equipment, test and measurement equipment, audio and visual equipment, home electronic appliances, machine tools, personal electronic equipment and industrial robots.

"Special": Transportation equipment (automobiles, trains, ships, etc.), traffic control systems, anti-disaster systems, anti-crime systems, safety equipment and medical equipment (not specifically designed for life support).

"Specific": Aircraft, aerospace equipment, submersible repeaters, nuclear reactor control systems, life support systems and medical equipment for life support, etc.

The quality grade of NEC Electronics products is "Standard" unless otherwise expressly specified in NEC Electronics data sheets or data books, etc. If customers wish to use NEC Electronics products in applications not intended by NEC Electronics, they must contact an NEC Electronics sales representative in advance to determine NEC Electronics' willingness to support a given application.

(Note)

- (1) "NEC Electronics" as used in this statement means NEC Electronics Corporation and also includes its majority-owned subsidiaries.
- (2) "NEC Electronics products" means any product developed or manufactured by or for NEC Electronics (as defined above).